

MERKEL V-PACKING SET ES/ESV



Merkel V-Packing Set ES or type ESV are multi-part seal sets for sealing piston rods, comprising one pressure ring, at least three V-rings and one support ring. The V-packing sets are available in three different versions:

Type A has 3 to 5 rubber/fabric seals, and can be installed in adjustable and non-adjustable housings.

Type B has 3 to 5 rubber/fabric seals, a rubber-mounted support ring with integrated rubber springs, and can be installed in non-adjustable housings. This type offers constant axial pre-stress.

Type C has 2 to 4 rubber/fabric seals, one rubber seal and can be installed in adjustable and non-adjustable housings. This type offers an enhanced sealing effect.

Type A and Type B can be supplied as open versions. Type C is always supplied as an endless version.

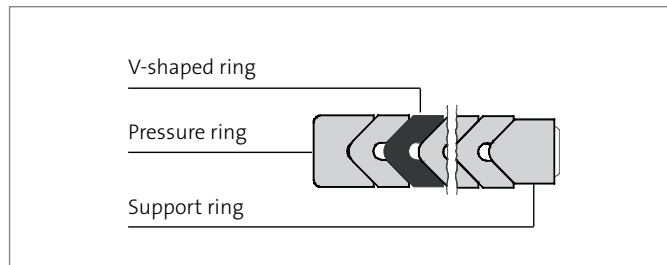

Applications

Seal set for tough applications, predominantly for spares supply at old installations.

VALUE TO THE CUSTOMER

- Field-proven under ultra-tough conditions
- Long useful lifetime
- Can be optimally matched to the application concerned
- Functions for a certain period even on poor surfaces
- Depending on the application and design involved, fluctuations in the leakage and friction behavior must be anticipated



FEATURES AND BENEFITS

Material

Pressure ring

Type	Material	Designation
ES	Cotton fabric/NBR	BI-NBR
ESV	Cotton fabric/FKM	BI-FKM

Support ring

Type	Material	Designation
ES	Cotton fabric/NBR or POM	BI-NBR or POM
ESV	Cotton fabric/FKM	BI-FKM

Roof-shaped ring

Type	Material	Designation
ES	Cotton fabric/NBR	BI-NBR
ESV	Cotton fabric/FKM	BI-FKM

Type	Material	Designation
ES	NBR	85 NBR
ESV	FKM	85 FKM

Operating conditions

Material	BI-NBR/85 NBR	BI-FKM
Hydraulic oils, HL, HLP	-30 ... +100 °C	-15 ... +140 °C
HFA fluids	+5 ... +60 °C	+5 ... +60 °C
HFB fluids	+5 ... +60 °C	+5 ... +60 °C
HFC fluids	-30 ... +60 °C	-15 ... +60 °C
HFD fluids	-	-15 ... +140 °C
Water	+5 ... +100 °C	+5 ... +80 °C
HETG (rape-seed oil)	-30 ... +80 °C	-15 ... +80 °C
HEES (synth. ester)	-30 ... +80 °C	-15 ... +100 °C
HEPG (glycol)	-30 ... +60 °C	-15 ... +80 °C
Mineral greases	-30 ... +100 °C	-15 ... +140 °C
Pressure	40 MPa	40 MPa
Sliding speed	0,5 m/s	0,5 m/s

Surface finish

Peak-to-valley heights	Ra	Rmax
Sliding surface	0,05 ... 0,3 µm	≤2,5 µm
Groove base	≤1,6 µm	≤6,3 µm
Groove sides	≤3,0 µm	≤15,0 µm

Material content $M_v > 50\%$ to max. 90%, with cut depth $c = R_v/2$ and reference line $C_{ref} = 0\%$

The long-time behavior of a sealing element and its dependability against early failures are crucially influenced by the quality of the counterface.

A precise description and assessment of the surface is thus indispensable. Based on recent findings, we recommend supplementing the above definition of surface finish for the sliding surface by the characteristics detailed in the table below. With these new characteristics derived from the material content, the hitherto merely general description of the material content is significantly improved, not least in regard to the abrasiveness of the surface. Please also consult our technical manual.

Surface finish of the sliding surfaces

Characteristic value	Limit	
Ra	>0,05 µm	<0,30 µm
Rmax	<2,5 µm	
Rpkx	<0,5 µm	
Rpk	<0,5 µm	
Rk	>0,25 µm	<0,7 µm
Rvk	>0,2 µm	<0,65 µm
Rvkx	>0,2 µm	<2,0 µm

The limit values listed in the table do not currently apply for ceramic or semi-ceramic counterfaces. Please also consult our technical manual.



FEATURES AND BENEFITS

Design notes

Please note our general design notes in our technical manual.

Gap dimension

In the case of the ES and ESV series, the gap on the side facing away from the pressure will depend on the metal guide being used, and the fit pairing. In order to avoid gap extrusion, the fits listed in the table below should be used. Please also consult our technical manual.

Nominal- \varnothing d [mm]	d
≤80	H9/f8
>80 ... 120	H8/f8
>120 ... 500	H8/f7
>500 ... 630	350 μ m
>630 ... 800	400 μ m
>800 ... 1.000	650 μ m
>1.000 ... 1.250	600 μ m

Tolerances

Diameter D [mm]	Tolerance
≤500	H11
>500	H10

Housing

Re-adjustable housings have the advantage of an optimal adjustment option for the sealing effect with minimal idling friction. After a lengthy period of running and incipient wear on the seal,

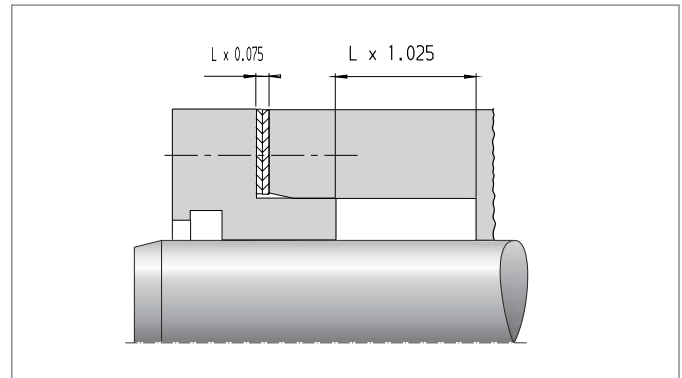

tightening the gland can extend the useful lifetime and significantly delay a system standstill. For re-adjustable housings, an extension of 2,5 % and a readjustability level of 7,5 % of the "L" dimension is recommended. Non-re-adjustable housings have the advantage of cost saving production, since shims are not required. For these housings, the Type B seal set is particularly recommended. The support ring with integrated rubber springs handles the function of initial compression and of re-adjustment continuously during operation. There is no need for maintenance of the seal. The seal set's lifetime is optimally utilized.

Installation & assembly

Careful fitting is a prerequisite for the correct function of the seal. Before installation all individual parts of the seal set must be greased. Mineral-oil-based greases can be used so long as they have a good seal-compatibility. The rod must be in the cylinder's installation space before installation. A Merkel V-Packing Set can also be mounted as a split version. This reduces dismantling work considerably. In this case the split sealing rings are wrapped around the plunger or the piston rod one by one and are pushed into the housing by an offset of the joint of 120° each. Please also consult our technical manual.



FEATURES AND BENEFITS

