

MERKEL RADIAMATIC R 55

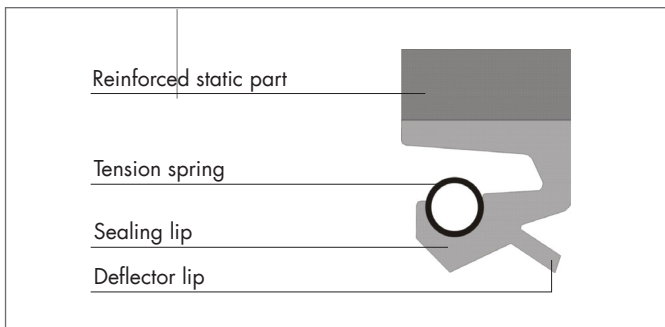

Merkel Radiamatic R 55 is a radial shaft seal consisting of a fabric reinforced section of sturdy design, firmly bonded to the rubber sealing lip. A helical tension spring assists radial contact pressure of the lip on the shaft. In order to protect the sealing lip against dirt ingress from the outside, a functionally decoupled deflector lip has been integrated.



VALUE TO THE CUSTOMER

- Integrated deflector lip instead of a secondary seal
- Reduced housing space – easy handling
- High shaft offsets possible due to special, non-interfering design of sealing and deflector lip
- High wear resistance and functionally aligned sealing and deflector lip for long performance
- Large diameter range (approx. 1.000 mm up to 3.000 mm) without mold cost

Applications

Merkel Radiamatic R 55 are mainly used as radial shaft seals for the main bearing in wind turbines.

Material

Sealing lip	Adhesive part	Tension spring
80 NBR B241	Impregnated cotton fabric	ST 1.4571
75 HNBR U467	Impregnated aramide fabric	ST 1.4571

Further material combinations on request.



FEATURES AND BENEFITS

Operating conditions

Material	80 NBR B241	75 HNBR U467
Mineral oils	-40 ... +100 °C	-30 ... +120 °C *
Water	+5 ... +100 °C	+5 ... +100 °C
Lubricating greases	-40 ... +100 °C	-30 ... +120 °C *
Rolling oil emulsion	on enquiry	on enquiry
Pressure	0,05 MPa	0,05 MPa
Sliding speed	5 m/s	5 m/s

Other media on demand. The figures given are maximum values and must not be applied simultaneously.

* See note "Low temperature duty in wind power mills" – extended temperature range.

Low temperature duty in wind power mills

Freezing of the materials during a standstill is completely reversible as soon as the temperature rises again.

When the rotors are spinning slowly or beginning to rotate, the temperature at the sealing lip will rise very swiftly.

This means static utilization down to -50 °C (-58 °F) is not problematic.

Surface finish

Peak-to-valley heights	R_a	R_{max}
Sliding surface	$\leq 0,6 \mu\text{m}$	$\leq 2,5 \mu\text{m}$
Housing	$\leq 4 \mu\text{m}$	$\leq 15 \mu\text{m}$

Machining is carried out most effectively by plunge grinding, i. e. without forward feed. The surface hardness should be approx. 60 HRC (min. depth of hardness 0,5 mm). The higher the peripheral speed the lower should be the surface roughness R_a of the mating surface. In order to ensure a sufficient lubricating film the surface should not be too smooth.

Standard value: $R_a \text{ min.} = 0,1 \mu\text{m}$.

Profile bearing length ratio $t_p > 50\%$ up to max. 90% at average depth $c = R_z/2$ and reference line $C_{ref} = 0\%$.

Abrasive surfaces, ridges, scratches and blow-holes are to be avoided.

Design notes

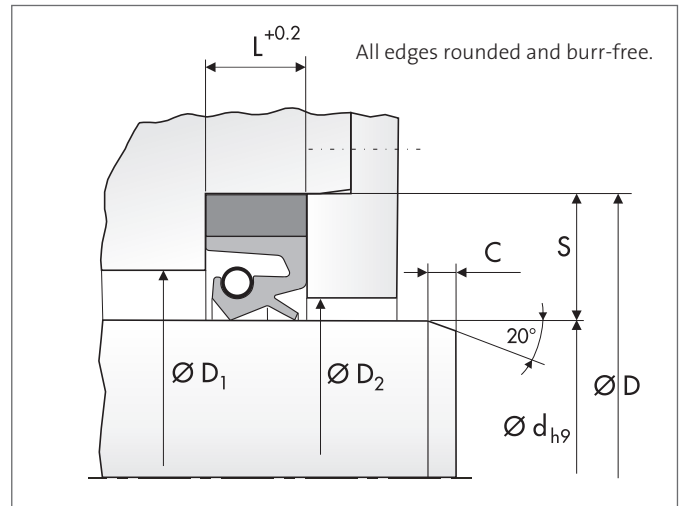

Please note the general design-related remarks in our technical manual.

Installation chamfers

See dimension "C" in table of dimensions.

Housing recommendations for new designs

Profile SxL [mm]	Diameter range [mm]
32 x 25	d = approx. 1000 ... 3000

Installation & assembly

An axially accessible housing is necessary for the radial shaft seal Merkel Radiamatic R 55, as a clamping force must be applied to the rings.

The rotary shaft seal is delivered with an over-sized height. To ensure reliable operation the seal must be axially pressed to the dimension "L". An open housing with a cover plate and tightening screws is necessary. Certain deformation forces are necessary for pressing, and the cover plate and tightening screws should be designed accordingly. Please ask us for guide values.