

MERKEL RADIAMATIC R 36

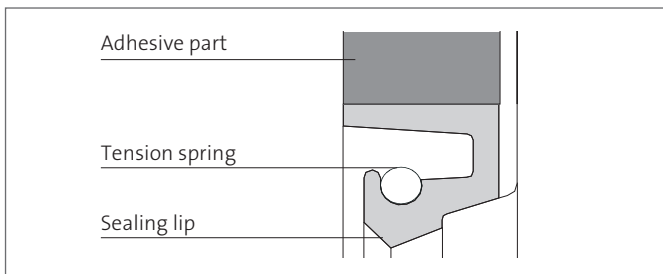

Merkel Radiamatic R 36 is a radial shaft seal consisting of a fabric reinforced section of sturdy design, firmly bonded to the rubber sealing lip. A helical tension spring assists radial contact pressure of the lip on the shaft.



Applications

Shaft seals Merkel Radiamatic R 36 are mainly used in heavy duty applications like rolling mills or large size gear boxes.

Material

Sealing lip	Adhesive part	Tension spring
80 NBR 245565	Impregnated cotton fabric	ST 1.4571
80 NBR B241	Impregnated cotton fabric	ST 1.4571
75 HNBR U467	Impregnated aramide fabric	ST 1.4571
80 FKM K670	Impregnated aramide fabric	ST 1.4571

Further material combinations on request.

VALUE TO THE CUSTOMER

- Highly wear resistant
- Constant radial force assuring steady performance
- Also available as joint-on-site version
- Supportive elements for the sealing lip allow higher pressures. Elevated pressures require endless seals. Drawings of the support rings and further installation instructions are available on request.



FEATURES AND BENEFITS

Operating conditions

Material	80 NBR 245565	80 NBR B241	75 HNBR U467	80 FKM K670
Mineral oils	-20 ... +80 °C	-40 ... +100 °C	-30 ... +120 °C	-10 ... +180 °C
Water	+5 ... +80 °C	+5 ... +100 °C	+5 ... +100 °C	+5 ... +80 °C
Lubricating greases	-20 ... +80 °C	-40 ... +100 °C	-30 ... +120 °C	-10 ... +180 °C
Rolling oil emulsion	on enquiry	on enquiry	on enquiry	on enquiry
Pressure	0,05 MPa	0,05 MPa	0,05 MPa	0,05 MPa
Sliding speed	12 m/s	20 m/s	25 m/s	25 m/s

Other media on demand. The figures given are maximum values and must not be applied simultaneously.

Surface finish

Peak-to-valley heights	R_a	R_{max}
Sliding surface	$\leq 0,6 \mu\text{m}$	$\leq 2,5 \mu\text{m}$
Housing	$\leq 4 \mu\text{m}$	$\leq 15 \mu\text{m}$

Machining is carried out most effectively by plunge grinding, i. e. without forward feed. The surface hardness should be approx. 60 HRC (min. depth of hardness 0,5 mm).

The higher the peripheral speed the lower should be the surface roughness R_a of the mating surface. In order to ensure a sufficient lubricating film the surface should not be too smooth.

Standard value: $R_a \text{ min.} = 0,1 \mu\text{m}$.

Profile bearing length ratio $t_p > 50\%$ up to max. 90% at average depth $c = R_z/2$ and reference line $C_{ref} = 0\%$.

Abrasive surfaces, ridges, scratches and blow-holes are to be avoided.

Tolerances

$\varnothing D$ [mm]	Tolerances
<500	H8
>500	+0,0004 x D

Overall eccentricity

The permissible overall eccentricity (static and dynamic eccentricity) between shaft and housing is dependent on the seal Profile and circumferential speed. If necessary we will provide recommended values.

Housing recommendations for new designs

$\varnothing d$ [mm]	S (Profile) [mm]	L [mm]
>100	20	16
>250	22	20
>450	25	22
>750	32	25

Installation & assembly

An axially accessible housing is necessary for the radial shaft seal Merkel Radiamatic R 36, as a clamping force must be applied to the ring.

The rotary shaft seal is delivered with an over-sized height. To ensure reliable operation, the seal must be axially pressed to the dimension "L". An open housing with a cover plate and tightening screws is necessary. Certain deformation forces are necessary for pressing, and the cover plate and tightening screws should be designed accordingly. Please ask us for guide values.



FEATURES AND BENEFITS

Design notes

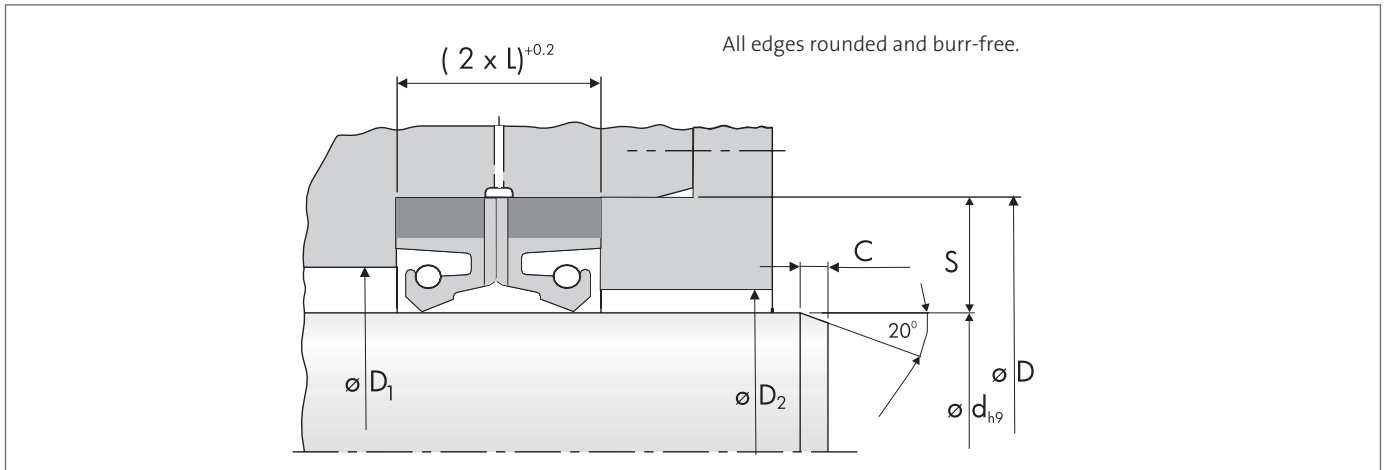

Please note the general design-related remarks in our technical manual.

Installation chamfers

See dimension "C" in table of dimensions.